

**CATHODIC PROTECTION STANDARD DRAWINGS  
TABLE OF CONTENTS**

<b><u>DRAWING NO.</u></b>	<b><u>DESCRIPTION</u></b>	<b><u>DATE</u></b>
CP-1	TWO WIRE TEST STATION	7/2016
CP-2	FOUR WIRE AND INSULATOR TEST STATION	7/2016
CP-3	CASING TEST STATION	7/2016
CP-4	CONCRETE TEST BOX	7/2016
CP-5	CONCRETE METER BOX	7/2016
CP-6	WIRING DIAGRAM – TWO WIRE TEST BOX	7/2016
CP-7	WIRING DIAGRAM – 4 WIRE, CASING AND INSULATOR TEST BOX	7/2016
CP-8	TEST STATION LOCATION PLAN	7/2016
CP-9	ALUMINO-THERMIC WELD	7/2016
CP-9A	TEST WIRE CONNECTION – STEEL BAR ALTERNATE	7/2016
CP-10	PIPE JOINT BONDING FOR INLINE PIPE JOINTS	7/2016
CP-11	PIPE JOINT BONDING FOR PIPE FITTINGS	7/2016
CP-12	JOINT BONDING – CML&C STEEL PIPE	7/2016
CP-13	INSULATING FLANGE KIT ASSEMBLY	7/2016
CP-14	INSULATING FLANGE COATING ABOVE GRADE AND BURIED	7/2016

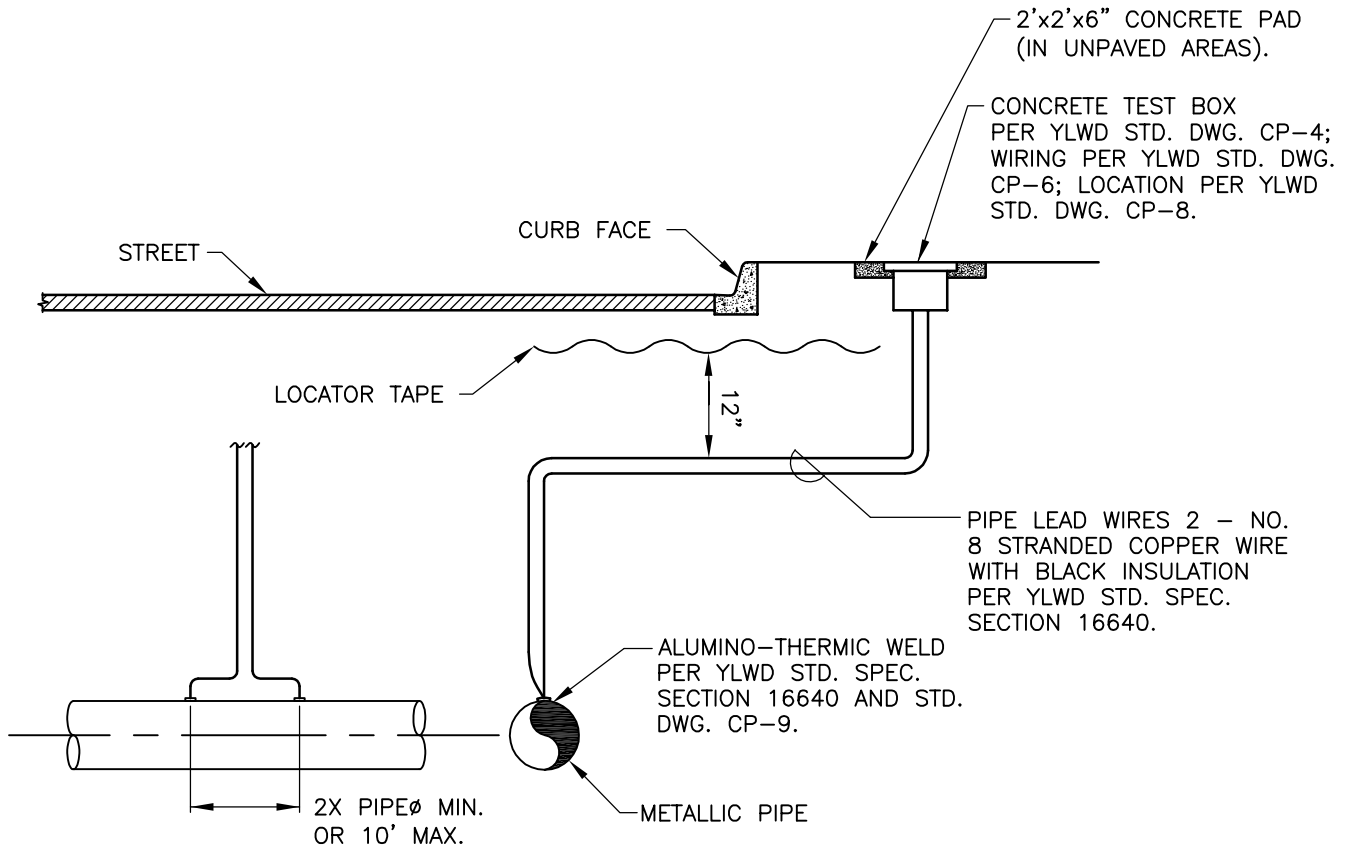

NOTES:

1. FOR TEST STATIONS INSTALLED CROSS COUNTRY OR IN UNPAVED AREAS, A UTILITY MARKER SHALL BE INSTALLED ADJACENT TO TEST STATION AND APPURTENANCES PER YLWD STD. SPEC. SECTION 15151 AND YLWD STD. DWG. G-1.
2. FOR TEST STATION LOCATIONS ON PIPES IN STREETS, SEE YLWD STD. DWG. CP-8.
3. WIRES SHALL BE WELDED TO TOP (HORIZONTAL) SURFACE OF PIPE.

APPROVED BY  
ENGINEERING  
MANAGER

DATE  
7/2016



YORBA LINDA WATER DISTRICT

TWO WIRE TEST STATION

STD. DWG.

CP-1

SHEET 1 OF 1

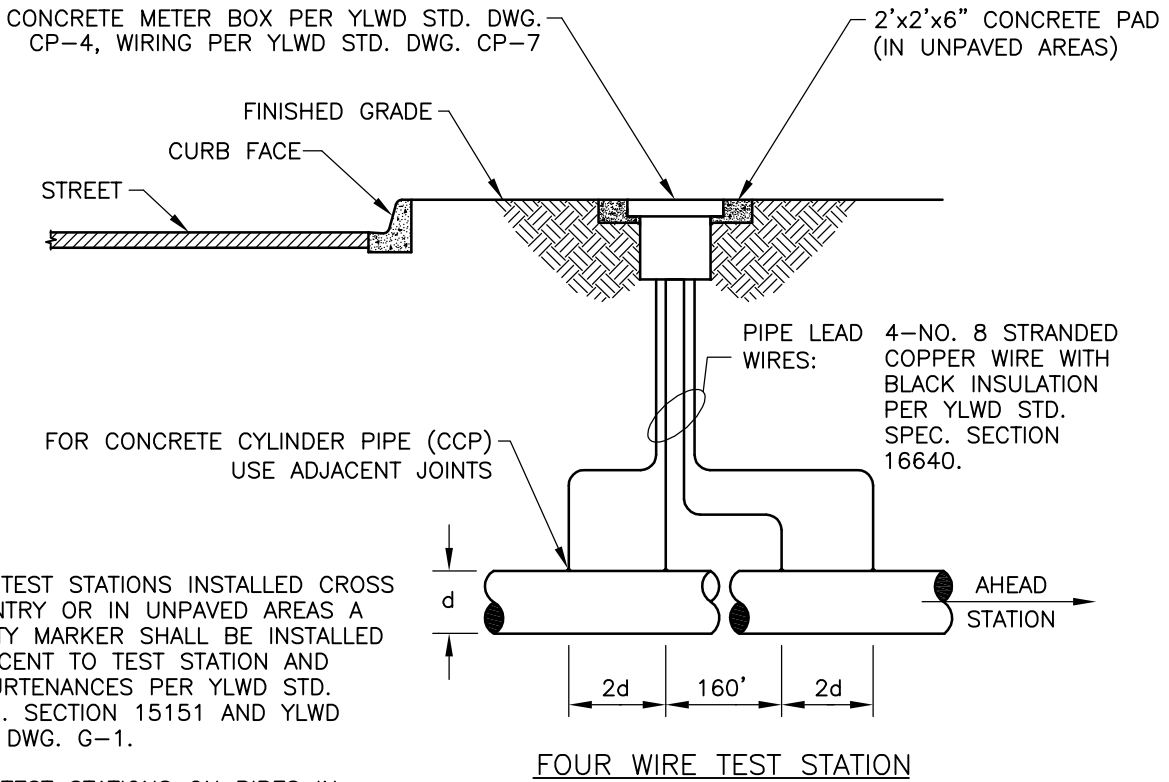
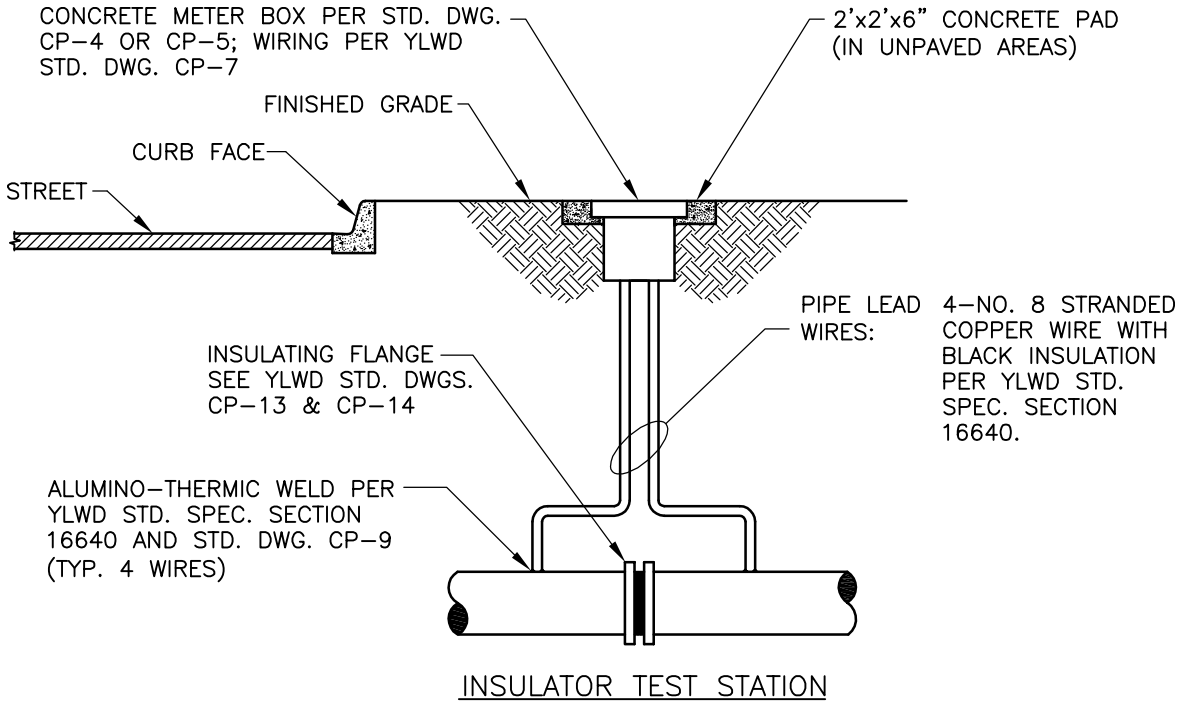

**NOTES:**

1. FOR TEST STATIONS INSTALLED CROSS COUNTRY OR IN UNPAVED AREAS A UTILITY MARKER SHALL BE INSTALLED ADJACENT TO TEST STATION AND APPURTENANCES PER YLWD STD. SPEC. SECTION 15151 AND YLWD STD. DWG. G-1.
2. FOR TEST STATIONS ON PIPES IN STREET, SEE YLWD STD. DWG. CP-8.

APPROVED BY ENGINEERING MANAGER		<b>YORBA LINDA WATER DISTRICT</b>	STD. DWG. <b>CP-2</b>
DATE  7/2016		<b>FOUR WIRE &amp; INSULATOR TEST STATION</b>	SHEET 1 OF 1

CONCRETE TEST BOX PER STD. DWG. CP-4 OR CP-5; WIRING PER YLWD STD. DWG. CP-7

2'x2'x6" CONCRETE PAD (IN UNPAVED AREAS)

FINISHED GRADE

PIPE LEAD WIRES:  
4-NO. 8 STRANDED COPPER WIRE WITH BLACK INSULATION PER YLWD STD. SPEC. SECTION 16640.

ALUMINO-THERMIC WELD PER YLWD STD. SPEC. SECTION 16640 AND YLWD STD. DWG. CP-9 (TYP. 4 WIRES)

ALUMINO-THERMIC WELD

CASING SEAL (TYP. 2 PLCS.)

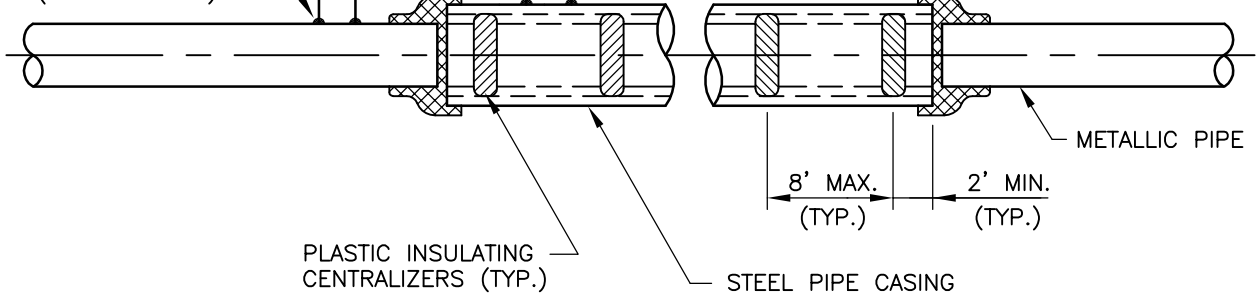

PLASTIC INSULATING CENTRALIZERS (TYP.)

STEEL PIPE CASING

METALLIC PIPE

8' MAX. (TYP.)

2' MIN. (TYP.)

NOTES:

1. FOR TEST STATIONS INSTALLED CROSS COUNTRY OR IN UNPAVED AREAS A UTILITY MARKER SHALL BE INSTALLED ADJACENT TO TEST STATION AND APPURTENANCES PER YLWD STD. SPEC. SECTION 15151 AND YLWD STD. DWG. G-1.
2. FOR TEST STATIONS ON PIPES IN STREET, SEE YLWD STD. DWG. CP-8.

APPROVED BY  
ENGINEERING  
MANAGER



DATE  
7/2016

YORBA LINDA WATER DISTRICT

CASING TEST STATION

STD. DWG.

CP-3

SHEET 1 OF 1

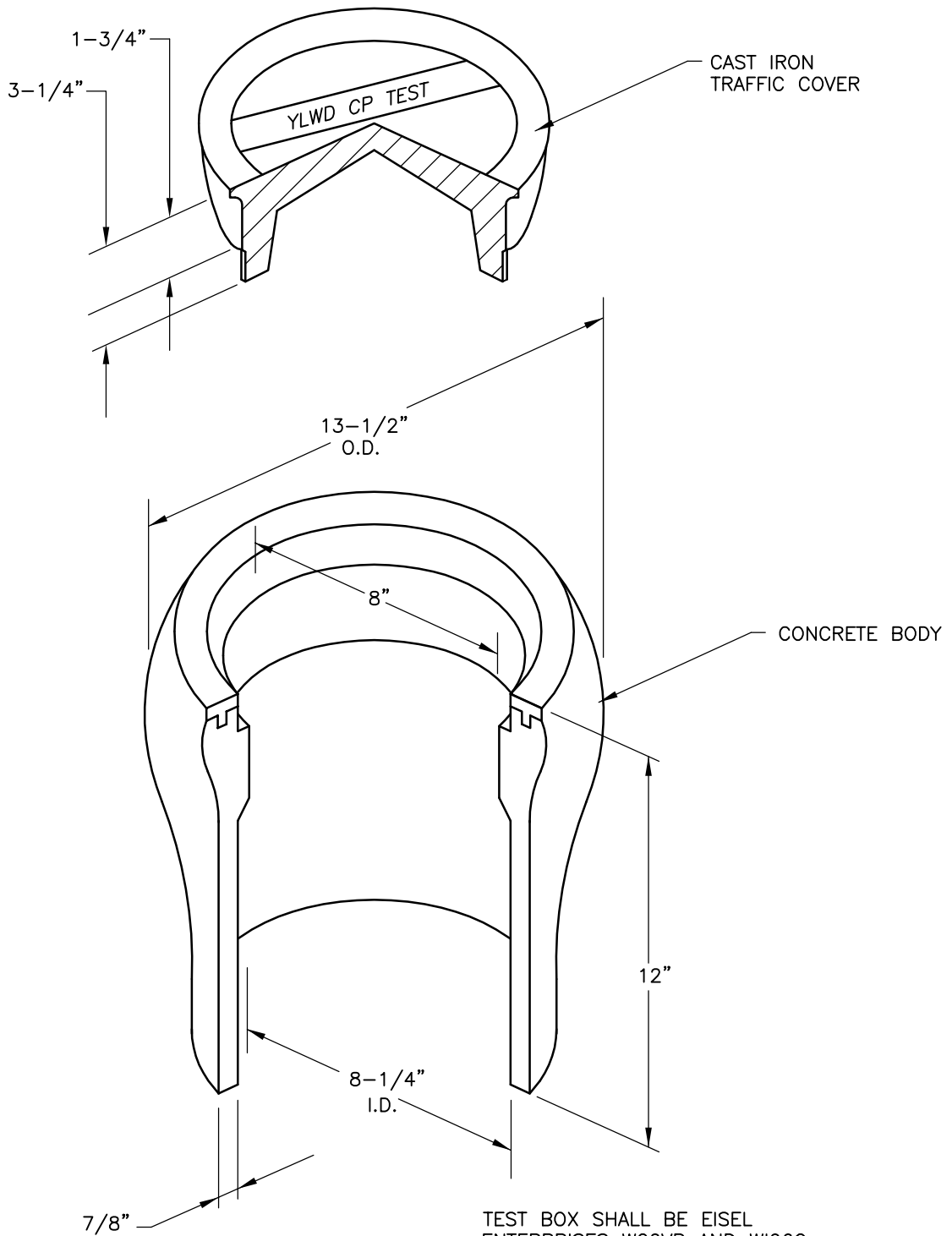

TEST BOX SHALL BE EISEL ENTERPRISES W20VB AND W106C, BROOKS PRODUCT 1RT, CHRISTY F08 OR APPROVED EQUAL.

APPROVED BY  
ENGINEERING  
MANAGER



DATE  
7/2016

YORBA LINDA WATER DISTRICT

CONCRETE CATHODIC PROTECTION TEST BOX

STD. DWG.

CP-4

SHEET 1 OF 1

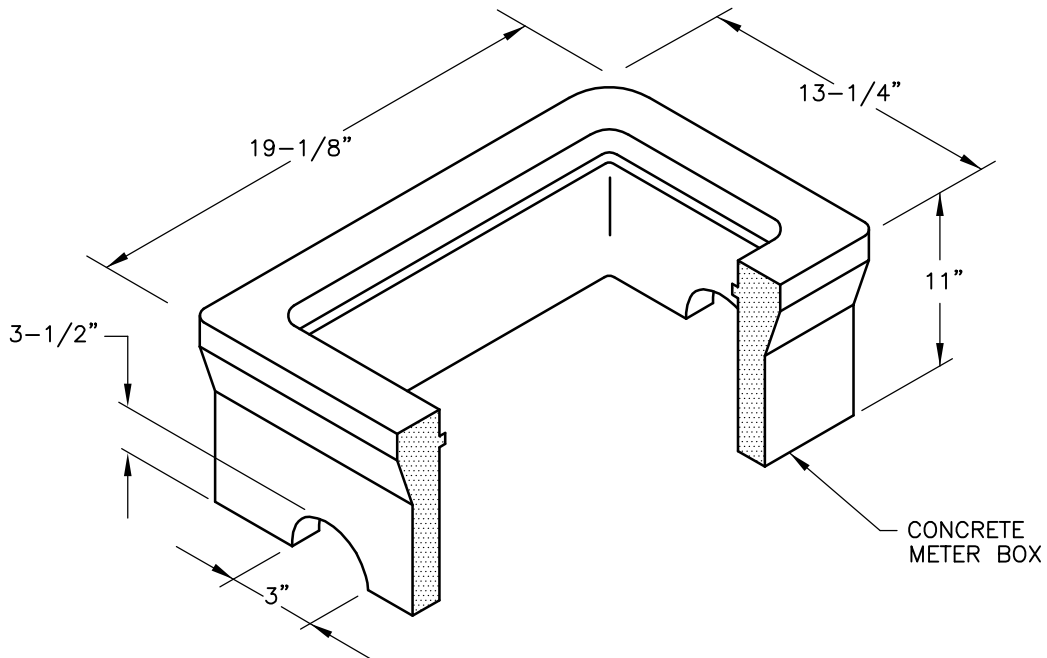
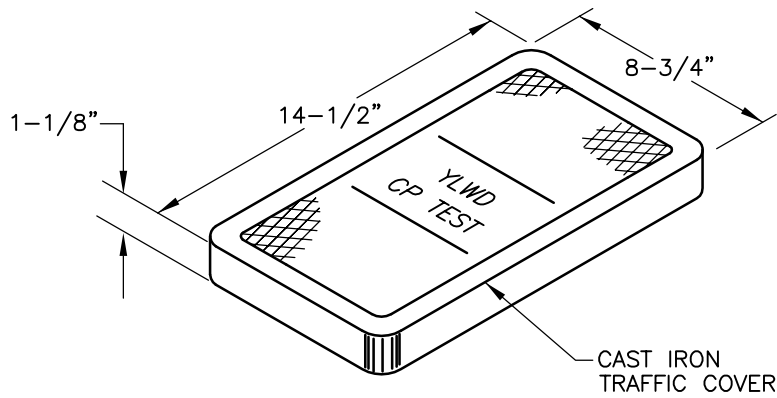

COVER WEIGHT: 13 LBS.  
BODY WEIGHT: 68 LBS.

APPROVED BY  
ENGINEERING  
MANAGER

DATE  
7/2016



YORBA LINDA WATER DISTRICT

CONCRETE METER BOX

STD. DWG.

CP-5

SHEET 1 OF 1

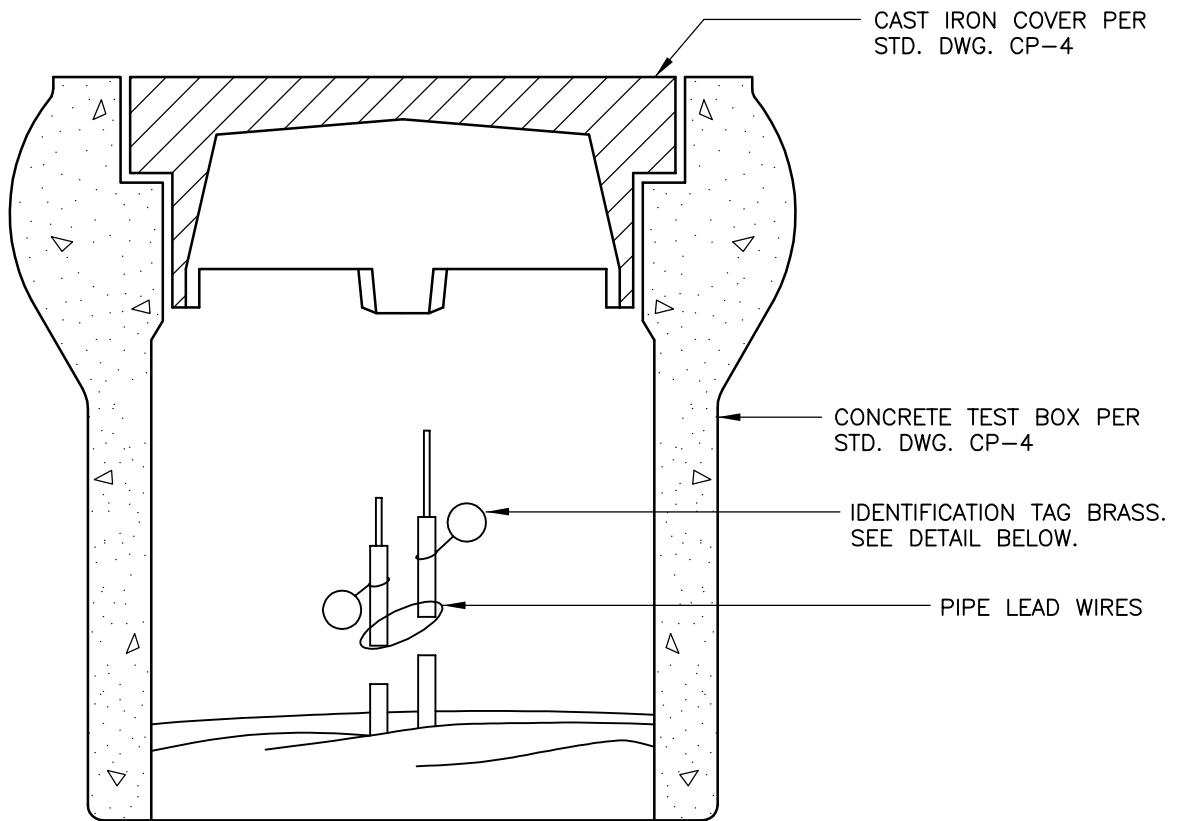

WIRING DIAGRAM

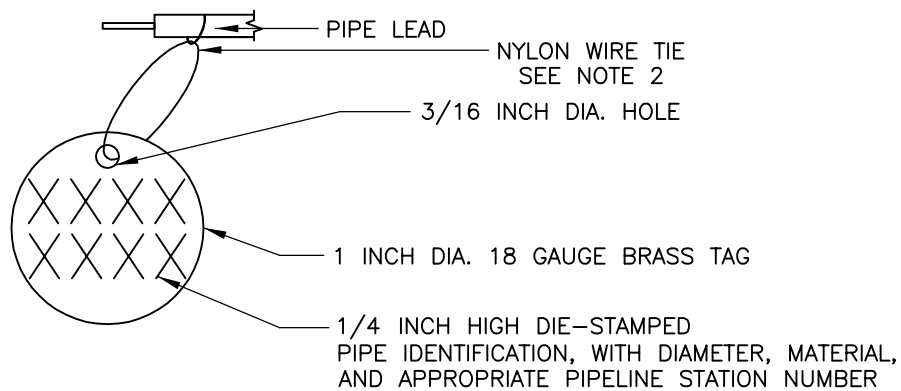

BRASS IDENTIFICATION TAG

NOTES:

1. LEAVE SUFFICIENT SLACK (3 FT. MIN.) IN LEAD WIRE COILED WITHIN TEST BOX.
2. TWO TIES REQUIRED, ONE TO SECURE TO BRASS TAG TO CABLE, AND ONE TO ALLOW COMPLETE ROTATIONAL FREEDOM WITHOUT BINDING.

APPROVED BY  
ENGINEERING  
MANAGER

DATE  
7/2016



YORBA LINDA WATER DISTRICT

WIRING DIAGRAM -TWO WIRE TEST BOX

STD. DWG.

CP-6

SHEET 1 OF 1

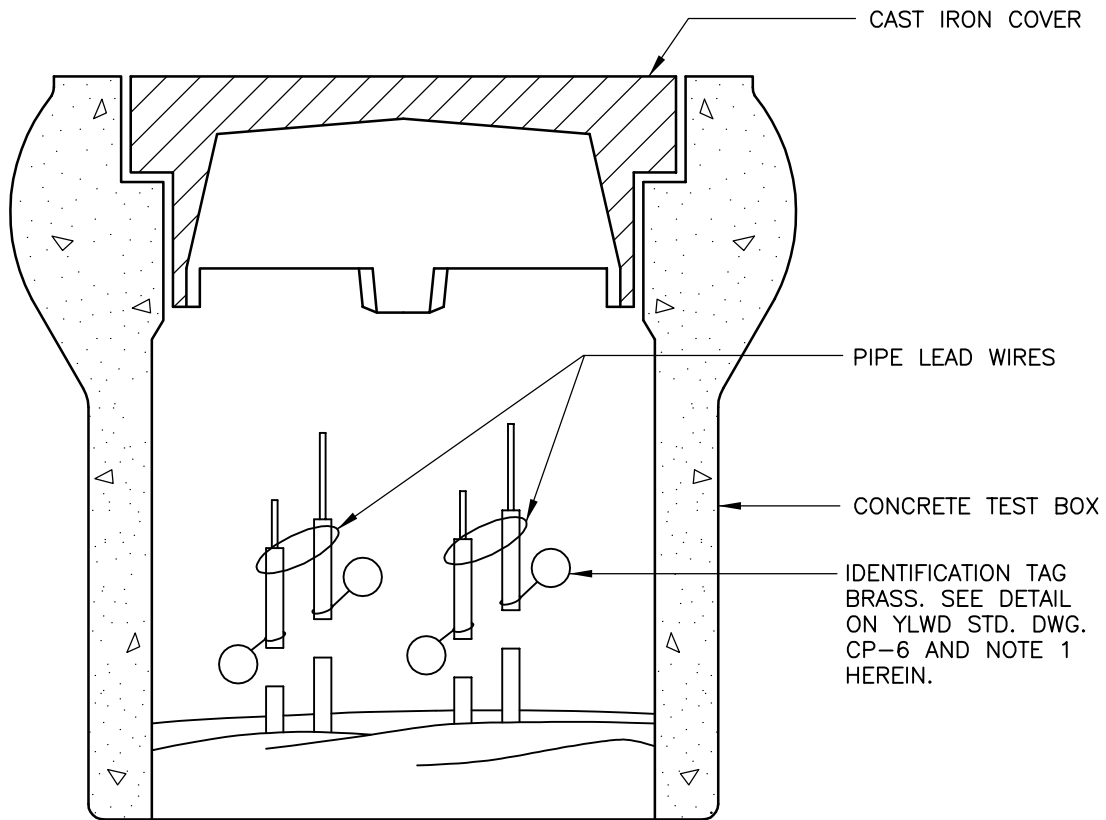

**NOTES:**

1. LEAD WIRES SHALL BE IDENTIFIED BY
  - A) PIPE DIAMETER
  - B) PIPE MATERIAL
  - C) APPROPRIATE PIPELINE STATION NUMBER
2. LEAD WIRES, IN CASING TEST BOX, SHALL BE IDENTIFIED WITH A (P) FOR PIPE AND (C) FOR CASING.
3. LEAD WIRES FOR INSULATOR TEST BOXES SHALL ALSO BE IDENTIFIED BY SIDE OF INSULATING FLANGE AS N & S (NORTH & SOUTH) OR E & W (EAST & WEST).
4. LEAVE SUFFICIENT SLACK (3 FT. MIN.) IN LEAD WIRES COILED WITHIN TEST BOX.

APPROVED BY ENGINEERING MANAGER		YORBA LINDA WATER DISTRICT	STD. DWG.
DATE 7/2016			WIRING DIAGRAM 4 WIRE, CASING & INSULATOR TEST BOX



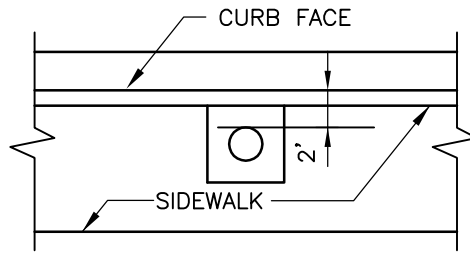

CASE I – SIDEWALK ADJACENT TO CURB

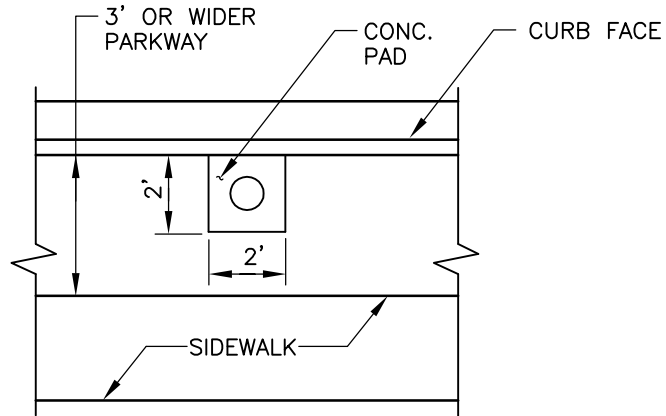

CASE II – SIDEWALK NOT ADJACENT TO CURB

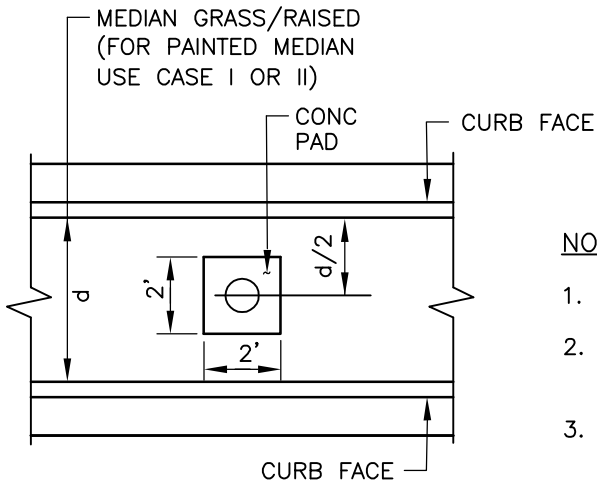

CASE III – CENTER MEDIAN

**NOTES:**

1. USE CASE I OR II FOR PIPE CLOSE TO THE CURB.
2. USE CASE III FOR PIPE CLOSE TO THE CENTER MEDIAN WHERE MEDIAN IS RAISED AND  $d > 10'-0"$ .
3. IF DIFFERENT FROM THESE THREE CASES, DISTRICT'S REPRESENTATIVE SHALL DETERMINE THE TEST STATION LOCATION.

APPROVED BY  
ENGINEERING  
MANAGER

DATE  
7/2016



YORBA LINDA WATER DISTRICT

TEST STATION LOCATION PLAN

STD. DWG.

CP-8

SHEET 1 OF 1

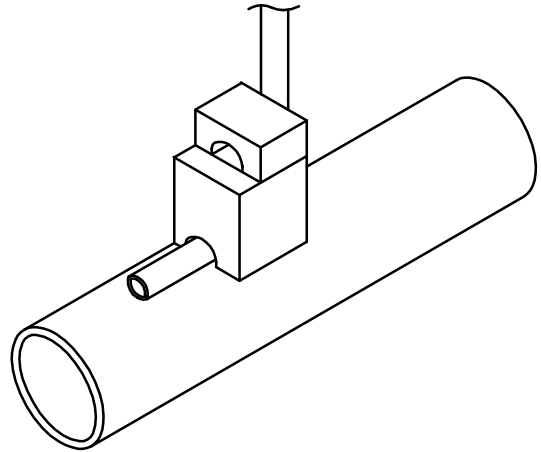
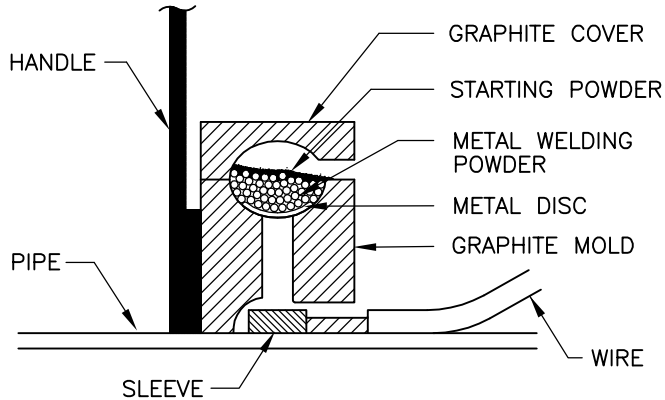

STEP 1. FILE STRUCTURE CONNECTION AREA (3"x3") TO BARE SHINY METAL AND CLEAN.

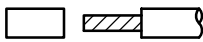

STEP 2. STRIP INSULATION FROM WIRE. ATTACH SLEEVE (REQUIRED ON NO. 10 AWG WIRE & SMALLER).

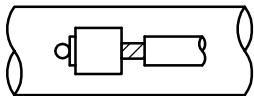

STEP 3. HOLD MOLD FIRMLY WITH OPENING AWAY FROM OPERATOR AND IGNITE WITH FLINT GUN.

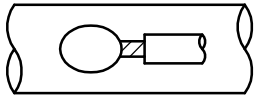

STEP 4. REMOVE SLAG FROM CONNECTION AND PEEN WELD FOR SOUNDNESS.

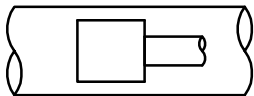

STEP 5. COVER CONNECTION AND EXPOSED STRUCTURE SURFACE WITH A BITUMINOUS COATING COMPOUND. PLACE PLASTIC SHIELD CAP FIRMLY OVER CONNECTION.

STEP 6. REPAIR PIPE COATING.

NOTES:

1. ALL WIRE WELDS SHALL BE APART AT MINIMUM 6 IN. CIR. AND 12 IN ALONG PIPE LENGTH.
2. STANDARD WELD CARTRIDGES SHALL BE USED FOR STEEL SURFACES. FOR DUCTILE IRON AND CAST IRON, USE XF-19 ALLOY OR EQUIVALENT.
3. WELDER SHOWN IS FOR HORIZONTAL SURFACES. FOR VERTICAL SURFACES, SIDE WELDER IS REQUIRED.
4. THERMIC WELD MOLD FIXTURES MAY HAVE TO BE MODIFIED TO FIT BETWEEN PRETENSION RODS OR TO THE BELL RING.

APPROVED BY  
ENGINEERING  
MANAGER

DATE  
7/2016



YORBA LINDA WATER DISTRICT

ALUMINO-THERMIC WELD

STD. DWG.

CP-9

SHEET 1 OF 1

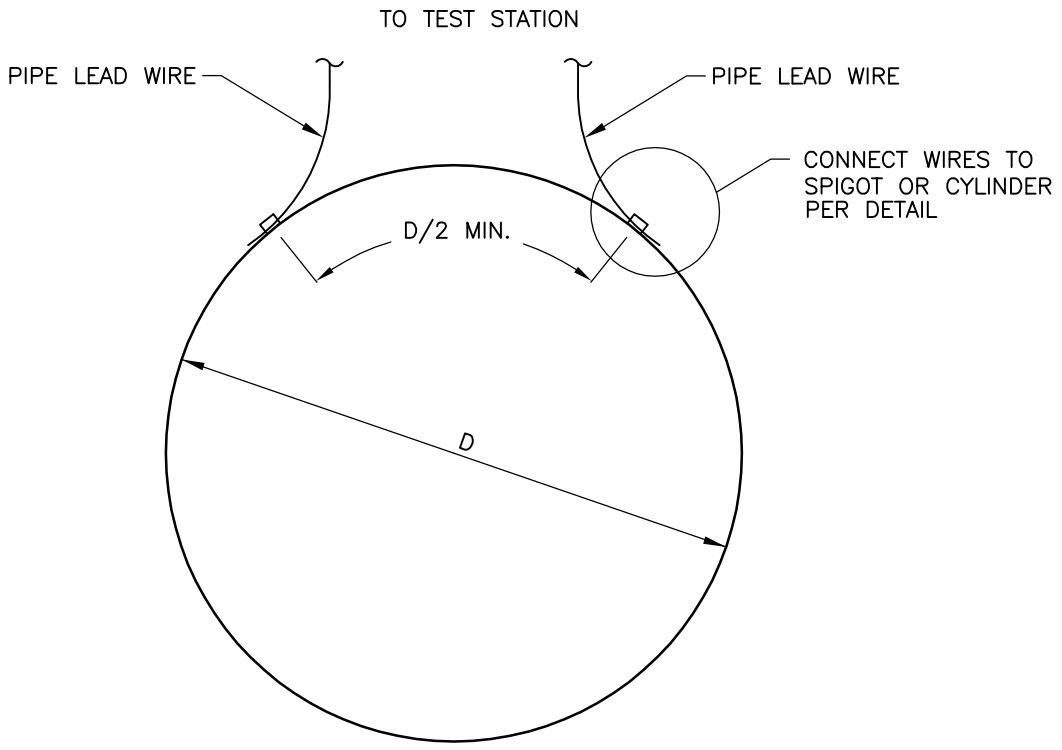

SECTION AT SPIGOT OR CYLINDER

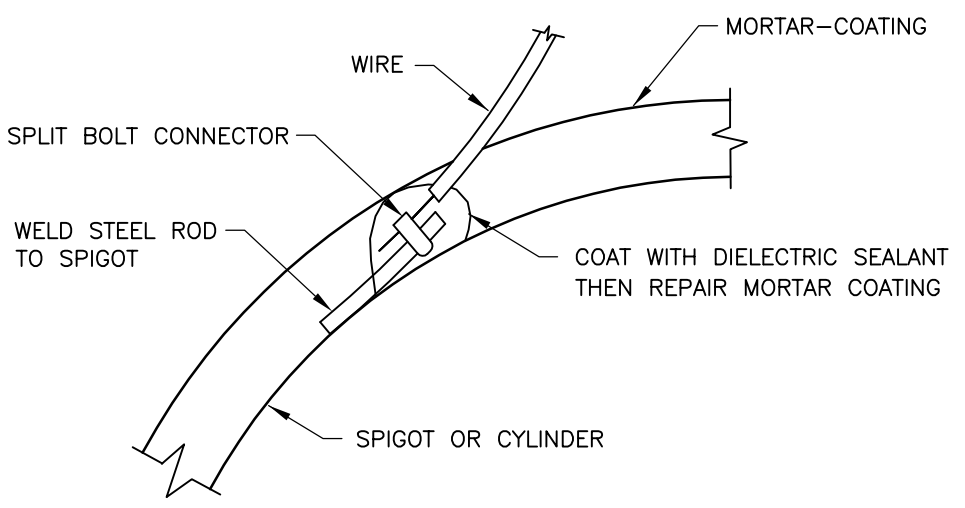

DETAIL

NOTE:

1. EXPOSE CYLINDER CAREFULLY SO AS NOT TO DAMAGE CYLINDER OR PRETENSION BARS.

APPROVED BY  
ENGINEERING  
MANAGER

DATE  
7/2016



YORBA LINDA WATER DISTRICT

TEST WIRE CONNECTION - STEEL BAR ALTERNATE

STD. DWG.  
CP-9A

SHEET 1 OF 1

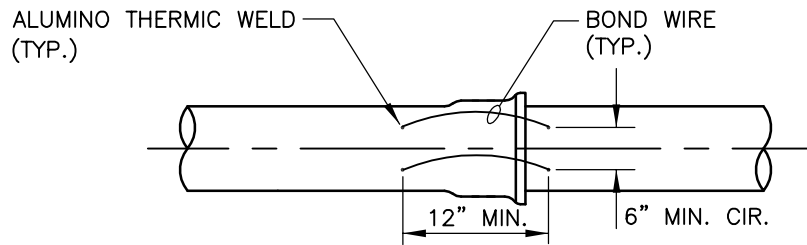

BELL AND SPIGOT PIPE JOINT

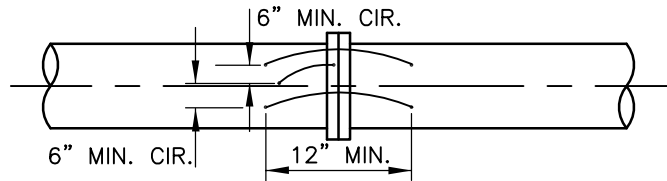

FLANGED PIPE JOINT

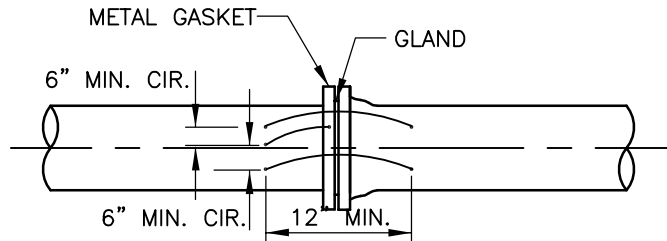

MECHANICAL PIPE JOINT

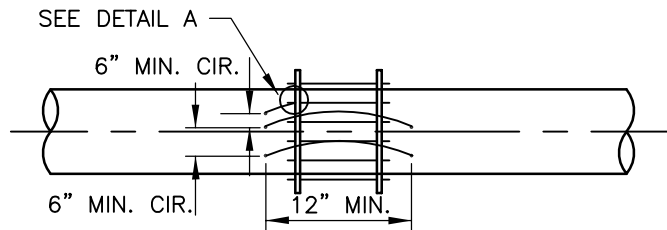

FLEXIBLE COUPLING PIPE JOINT

NOTES:

1. ALL WIRE WELDS SHALL BE 6" APART MIN.
2. BOND WIRES SHALL NOT BE INSTALLED ACROSS INSULATING JOINTS.
3. COAT WELD PER SPECIFICATIONS.
4. THREE BOND WIRES ARE REQUIRED FOR PIPE DIAMETERS 18" OR LARGER.
5. ENCASE FLEXIBLE COUPLING IN 8 MIL POLYETHYLENE WRAP.

COAT WIRE AND TERMINAL LUG WITH BITUMASTIC COATING

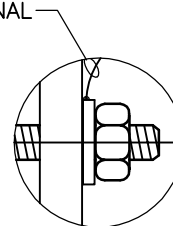

DETAIL A

WIRE CONNECTION TO FLANGE BOLT

APPROVED BY  
ENGINEERING  
MANAGER



DATE  
7/2016

YORBA LINDA WATER DISTRICT

PIPE JOINT BONDING FOR INLINE PIPE JOINTS

STD. DWG.

CP-10

SHEET 1 OF 1

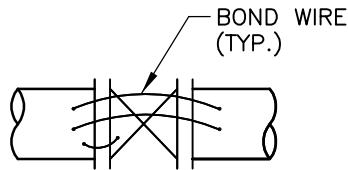

VALVE

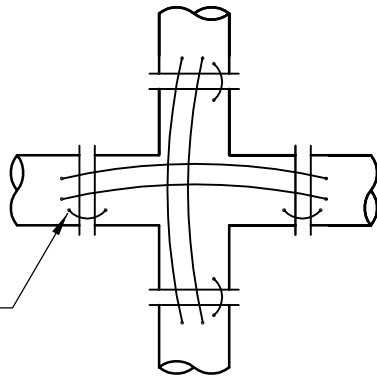

CROSS

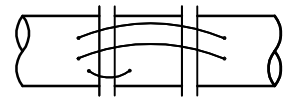

ADAPTER

ALUMINO THERMIC  
WELD PER  
YLWD STD. CP-9  
(TYP.)

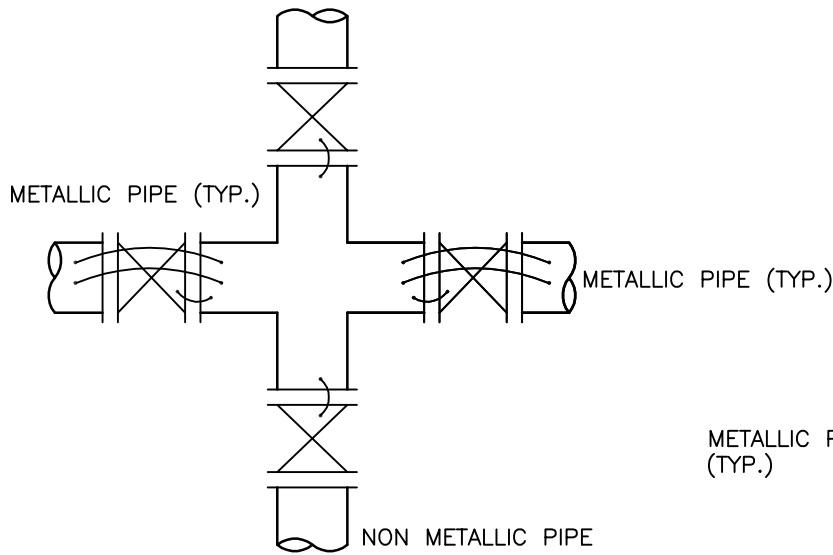

VALVE CROSSING

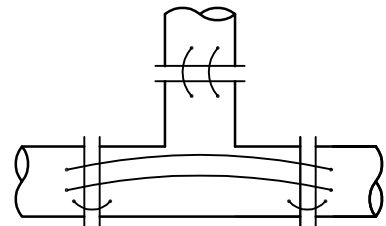

TEE

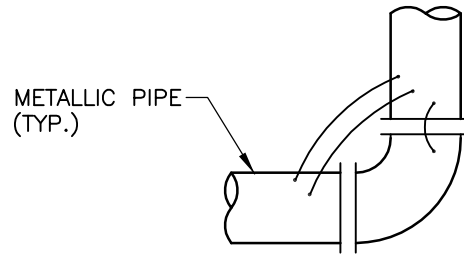

BEND

NOTES:

1. ALL BOND WIRES SHALL BE NO. 8 AWG. STRANDED COPPER WIRE WITH HMW/PE INSULATION.
2. ALL WIRE CONNECTIONS SHALL BE MADE BY THE ALUMINO-THERMIC WELD PROCESS. COAT WELD PER SPECIFICATIONS.
3. THREE BOND WIRES ARE REQUIRED FOR PIPE DIAMETERS 18" OR LARGER.
4. ALL WIRE WELDS SHALL BE APART AT MINIMUM OF 6" CIR. AND 12" ALONG PIPE LENGTH.

APPROVED BY  
ENGINEERING  
MANAGER

DATE  
7/2016



YORBA LINDA WATER DISTRICT

PIPE JOINT BONDING FOR PIPE FITTINGS

STD. DWG.

CP-11

SHEET 1 OF 1

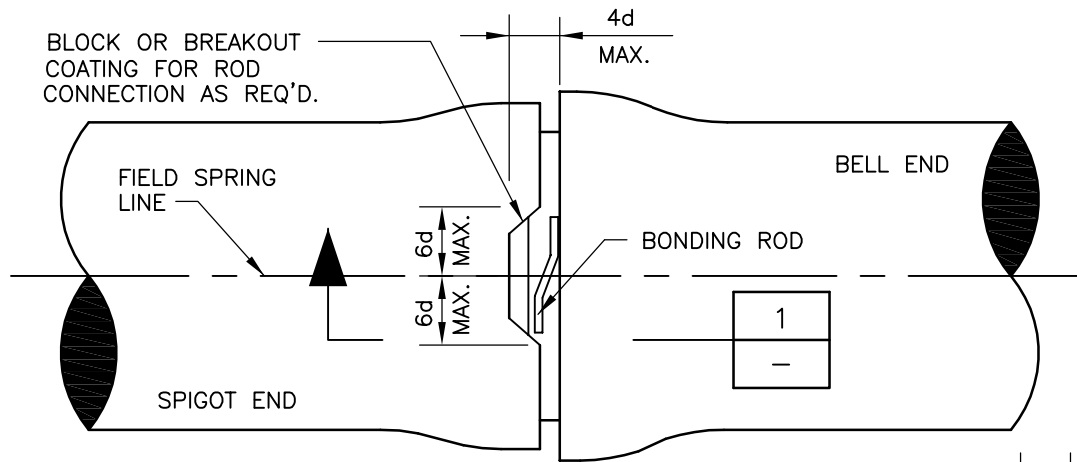

SIDE VIEW

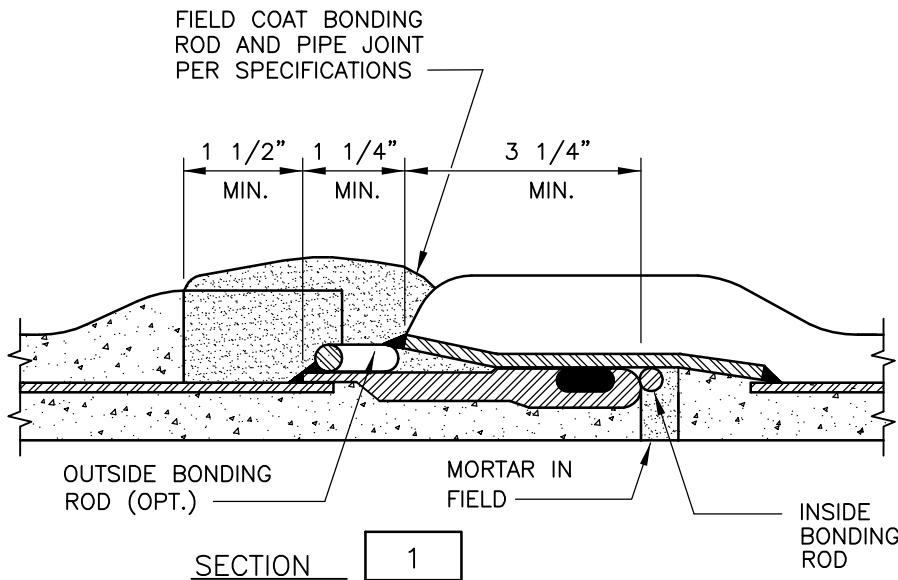

BONDING ROD DETAIL

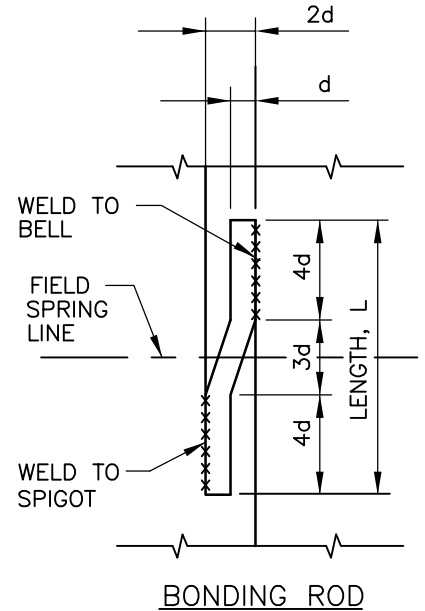

NOTE:

1. ALL PIPE JOINTS SHALL BE BONDED, EXCEPT FOR WELDED JOINTS.

PIPE DIA	UNDER 27"	27" AND LARGER
d	0.25"	0.50"
L	3.75"	5.50"
NO. OF RODS PER JOINT	2	3

APPROVED BY  
ENGINEERING  
MANAGER

DATE  
7/2016



YORBA LINDA WATER DISTRICT

JOINT BONDING - CML&C STEEL PIPE

STD. DWG.

CP-12

SHEET 1 OF 1

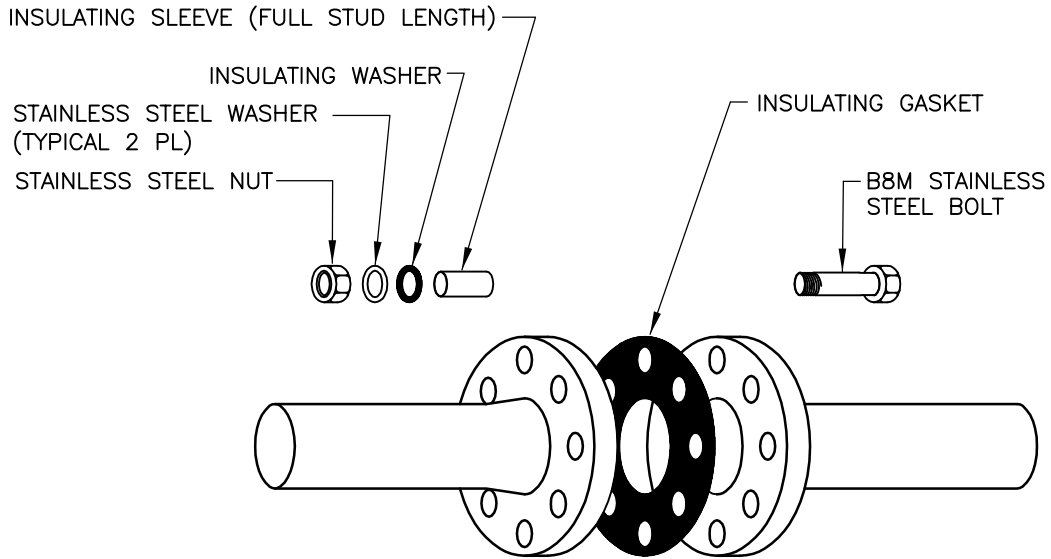

INSULATING FLANGE KIT

FOR INSULATING  
FLANGE COATING  
SEE STD. DWG.  
CP-14

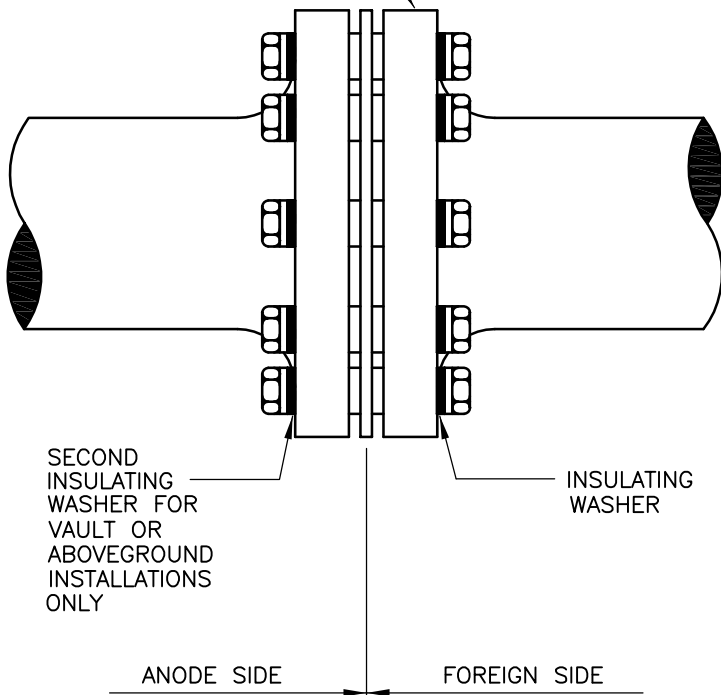

NOTES:

1. HARDWARE QUANTITIES IN INSULATING FLANGE KIT WILL VARY BASED ON GASKET PATTERN AND PIPE SIZE.
2. FOR BELOW GROUND INSTALLATIONS, INSTALL SINGLE-WASHER KITS WITH THE INSULATING WASHERS ONLY ON THE FOREIGN SIDE OF THE FLANGES.

APPROVED BY  
ENGINEERING  
MANAGER

DATE  
7/2016



YORBA LINDA WATER DISTRICT

INSULATING FLANGE KIT ASSEMBLY

STD. DWG.

CP-13

SHEET 1 OF 1

PRIMER AND WAX  
 TAPE COATING PER  
 YLWD STD. SPEC.  
 SECTION 16640.

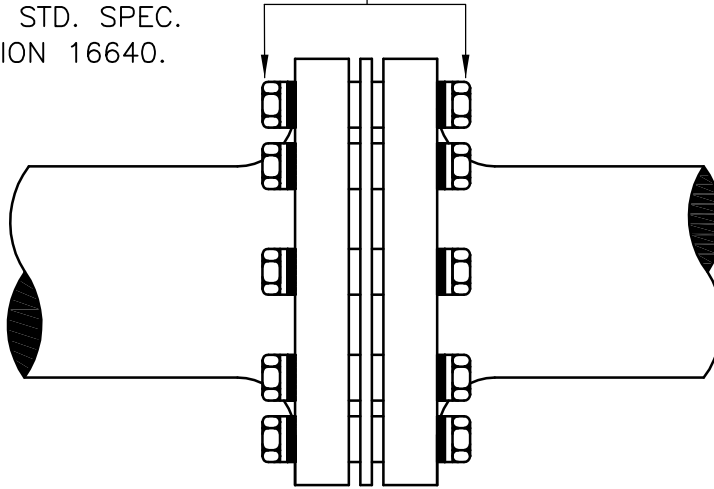

BURIED INSULATING FLANGE COATING

SELF FUSING ELASTIC  
 PUTTY TAPE, 2-LAYERS  
 HALF-LAPPED AROUND  
 FLANGE.

VINYL PLASTIC ELECTRICAL  
 TAPE, 2-LAYERS HALF-  
 LAPPED AROUND FLANGE.

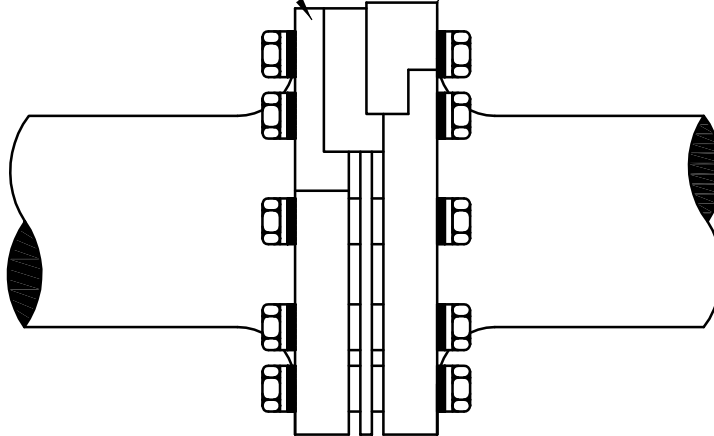

ABOVE GROUND INSULATING FLANGE COATING

APPROVED BY  
 ENGINEERING  
 MANAGER

DATE  
 7/2016



YORBA LINDA WATER DISTRICT

INSULATING FLANGE COATING  
 ABOVE GRADE & BURIED

STD. DWG.

CP-14

SHEET 1 OF 1